

Rack FX Emulations



FX that sound as good as they look!

iLive FX are top quality emulations and developments of popular industry standard effects modelled by our engineers right into the heart of the DSP mix engine. This gives you very low latency and instant access to all 8 FX at all times. No need for licences or complex configuration.

8 stereo 'RackExtra' FX engines

All iLive MixRacks, even the smallest, feature 8 built-in FX. These offer emulations of classic reverbs, delay, ADT, chorus, flangers and more.

* Early iLive systems had 2 FX—an upgrade to 8FX is available.

Build your rack of FX

The FX are arranged as a familiar rack. Load up to 8 FX units just as you would a traditional outboard rack. The panel layout even looks like the real thing. Load any combination from a library of 8 different FX types and over 80 factory presets.

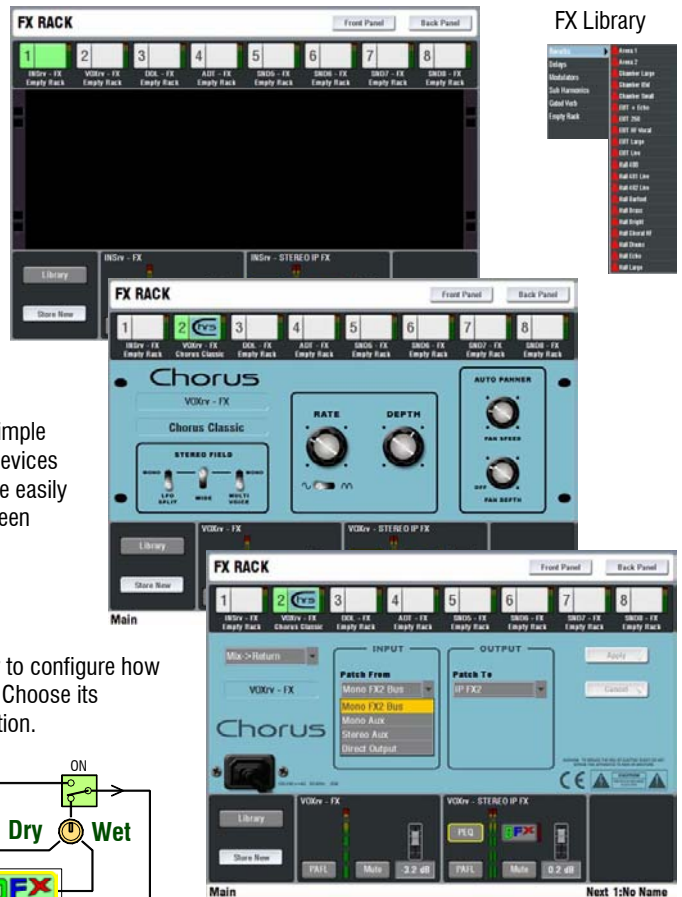

- Spatial Modelling Reverberator
- Gated Reverb
- 2 Tap Delay
- Automatic Double Tracker
- Chorus
- Flanger
- Symphonic Chorus
- Hypabass Sub-harmonic Synthesis

* Currently available with firmware 1.5

Front panel controls

The panel layouts have the simple analogue feel of the effects devices they emulate. Parameters are easily adjusted using the TouchScreen buttons and rotary control.

Back panel patching

Flip to the back panel view to configure how you want to use each FX. Choose its mode, source and destination.

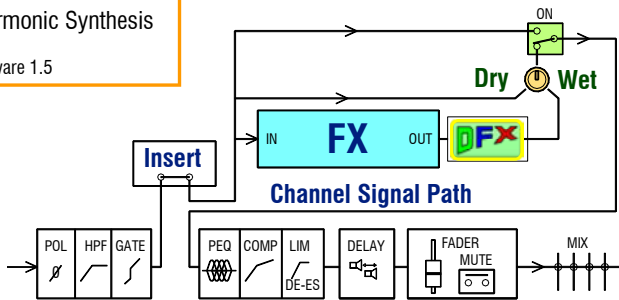

Mix bus or Direct Output

FX required for single channels, for example a dedicated vocal delay, can be driven from channel Direct Outputs to save using up buses.

Mix > Return FX

The familiar mix send / stereo channel return mode used with system effects such as reverb. You have a choice of returning via a pair of the 64 fully processed channels or using dedicated stereo FX returns with their own PEQ. These returns are in addition to the 64

Inserted FX

FX can be inserted into mono or stereo input or mix channels. The 'Dual Mono' mode lets you insert a stereo effect across two mono channels.

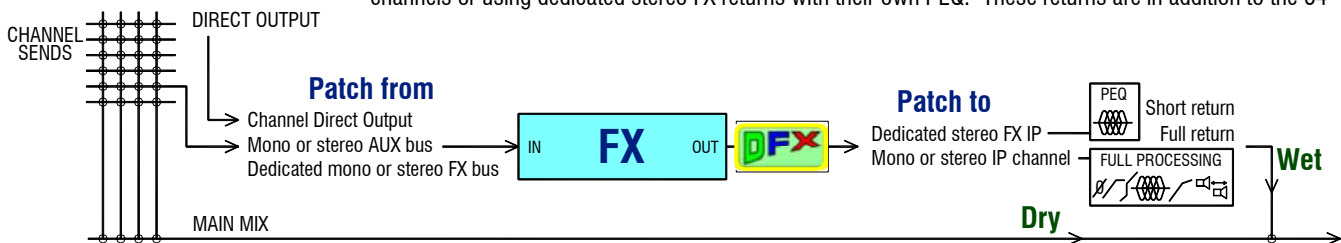

Store custom FX settings

BigVerb

Edit the factory settings to create your own Library presets for instant recall.

MySpace

Store and transfer FX libraries between systems using your USB key.



Add to Scene memories for recall per song, band or show.



Dynamik FX Shaper

All FX units feature DFX which can use the source to **Duck** or **Gate** the effect automatically. This provides dynamic control of the effect, for example to prevent reverb or echo swamping the signal during loud, busy passages.





FX that sound as good as they look!

iLive FX are top quality emulations and developments of popular industry standard effects modelled by our engineers right into the heart of the DSP mix engine. This gives you very low latency and instant access to all 8 FX at all times. No need for licences or complex configuration.



SMR Reverb is based around 4 complex spatial models—Classic, Hall, Room, EMT. Important parameters are always visible. ‘Expert’ pages add many more parameters as found on top end pro touring units.

Delay Generate separate left and right delay from a mono source, each with its own tempo. These can be linked for mono output. Tap the screen, dial the value or assign tap tempo to soft keys for delay from 5ms to 1.36 seconds. Controls let you adjust delay, feedback, filters and width to create a wide range of effects.

ADT Create classic automatic double tracking ‘doubler’ effects, voice thickening, vintage slap back tape delay loop emulation and more. Generate double or quad tracked voices from a mono source with stereo width enhancement and auto panning control.

Chorus re-creates the classic analogue chorus effects from the 80’s using 3 stereo field emulations which can be combined to create even more variation. Features a built-in LFO modulator and auto panner.

Flange provides 3 emulations—subtle airy ‘Ambient’, classic silky tape based ‘Vintage’, and an untameable ‘Wild’ effect. Classic pedal flangers were researched and their many LFO modulation, regeneration and stereo splitting effects implemented here.

Symphonic is a faithful emulation of this frequently requested classic 80’s chorus. Using just two controls it produces a rich and lively chorus sound with suggestion of mild phasing. Two presets satisfy the popular live sound application—SymphonicVox and SymphonicStrings.

Hypabass is a sub-harmonic synthesizer classically used live to generate infra (lower than 35Hz) and sub bass (35-70Hz) from weaker bass programme. It features very low distortion and separate control of these two frequency spectrums.

Gated Verb emulates the traditional gated reverb effect with ‘panned’ and ‘powerbox’ presets and the addition of many controls to shape the envelope, adjust diffusion and width, and filter the sound. It brings the 80’s effect right up to date with a visual representation of the gate time domain envelope.

Reverbs	& Arena 1
Delays	& Arena 2
Modulators	& Chamber Large
Sub Harmonics	& Chamber Mid
Gated Verb	& Chamber Small
Empty Rack	& EMT + Echo
	& EMT 250
	& EMT HF Vocal
	& EMT Large
	& EMT Live
	& Hall 480
	& Hall 481 Live
	& Hall 482 Live
	& Hall Barfoot
	& Hall Brass
	& Hall Bright
	& Hall Choral HF
	& Hall Drums
	& Hall Echo
	& Hall Large
	& Hall Massive
	& Hall Natural Small
	& Hall Small Vocal
	& Hall Small/Stage
	& Hall Strings
	& Hall Wide Large
	& Hall Wide Small
	& Overheads
	& Plate Big Echo
	& Plate Bright
	& Plate Gold Dly'd
	& Plate Gold US
	& Plate Keys Barfoot
	& Plate Perc
	& Plate Small Space
	& Plate Snare
	& Plate Vocal
	& Plate Vocal F
	& Room KickBox
	& Room Live Drums
	& Room PianoBar
	& Room Small
	& Room Speech
	& Slap Reverse
	& Slap Verb
	& Delay 2tap
	& Delay Brass
	& Delay Kraftwerk
	& Delay Perc
	& Delay Sax
	& Delay Shimmer
	& Delay Slap
	& Delay Stereo
	& Delay Vocal
	& Delay Vocal2
	& ADT 2Trk Vox
	& ADT Choral Dly
	& ADT Classic
	& ADT EkoChorus
	& Chorus Bright
	& Chorus Classic
	& Chorus Deep
	& Flange Classic
	& Flange Hard
	& Flange Jangle
	& Flange Space
	& SymphonicVox
	& SymphonyStrings
	& BEWARE Infra
	& Lost Fundamental
	& Gate Echo
	& Gate RevPan
	& Gate Short
	& Gated Big Pan
	& Gated Drum Big
	& Gated Drums Sml
	& Gated Kick
	& Gated Rev
	& Gated Snare
	& Gated Vocal